



DMW2 LED

Wet Location | Vapor-Tight Luminaire

Easier to Handle, Faster to Install.

Building on our reputation for providing the “best value in lighting”, the DMW2 LED from Lithonia Lighting® is the most innovative wet location/vapor-tight luminaire on the market. Designed by the contractor, for the contractor - the DMW2 gives you all the performance of a traditional 4-foot fluorescent fixture in a smaller, low-profile design optimized for LED.

Maximizing the benefits of LED technology, DMW2 LED provides application versatility, higher on-task light levels and energy-saving controls options for demanding environments.

Built for every application.

Right out of the box, the DMW2 LED is ready for a variety of applications including transit stations, food-processing plants, awnings, canopies, loading docks, car washes, stairwells, parking garages and more!

Easy to Install.

Innovative two-piece, plug-and-play design for simple one-person installation.



- 2,000, 3,000 and 4,000 lumen packages at 80 CRI
- Replaces 3 – 32W T8 or 2 – 54W T5HO lamps
- Suitable for -4°F (-20°C) to 104°F (40°C) ambient environments; 4000LM rated for -40°F (-40°C)
- Ceiling, wall, pendant, suspended or junction-box mounting options
- IP65, IP66, 1500 PSI hose-down
- Integral emergency battery pack



DesignLights Consortium® (DLC) qualified product; please check the DLC Qualified Products List at www.designlights.org/ to confirm which versions are qualified.

STOCK CONFIGURATIONS

Ci Code	Description	UPC
*234MU5	DMW2 L24 2000LM AFL MD MVOLT GZ10 40K 80CRI	889804321548
*234MU8	DMW2 L24 3000LM AFL MD MVOLT GZ10 40K 80CRI	889804321562
*234MUA	DMW2 L24 4000LM AFL MD MVOLT GZ10 40K 80CRI	889804321586
*234MUE	DMW2 L24 2000LM AFL MD MVOLT GZ10 50K 80CRI	889804321609
*234MUF	DMW2 L24 3000LM AFL MD MVOLT GZ10 50K 80CRI	889804321616
*234MUR	DMW2 L24 4000LM AFL MD MVOLT GZ10 50K 80CRI	889804321692

DMW2 LED

Small in Size. Big on Benefits.

The compact size of the DMW2 defies conventional, "bigger is better" thinking. It's bound to be your new go-to fixture for affordable, general-illumination lighting.

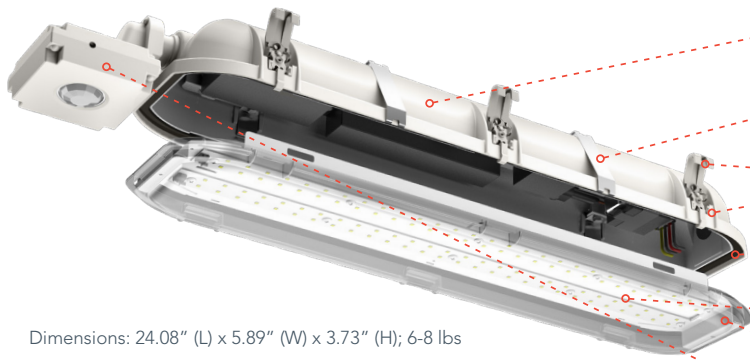

Dimensions: 24.08" (L) x 5.89" (W) x 3.73" (H); 6-8 lbs

Listings include: IP65 & IP66 rated, 1500 PSI hose-down (all sensors excluded), and rated for -4°F (-20°C) to 104°F (40°C) ambient temperatures, 4000LM rated for -40°F (-40°C)

- **5VA rated fiberglass housing** maintains ratings without covered canopy
- **Stainless steel mounting brackets #316** corrosion-resistant and holds up to the most demanding applications
- **Polymeric or stainless captive latches** stay out of the way during the install
- **NEMA 4X gasket** ideal for cold storage, won't expand and contract to take on water
- **Injection-molded lens** built to withstand impact, clear or frosted
- **One-piece optical assembly** combined reduce install time
- **Integrated Controls** include nLight® Air wireless, occupancy sensors, photocells and dimming controls

Choose the nLight® AIR enabled wireless controls option for the best controls solution. Reducing labor costs has never been easier for your demanding environment.

- 900 MHz wireless communication frequency easily penetrates typical obstructions found in commercial buildings like concrete
- Embedded sensors in luminaires simplify design and installation
- The CLAIRITY™ Pro mobile app simplifies startup and configuration without specialized tools or software
- The wireless adapter enables wired and wireless nLight devices to operate on one platform, utilize one suite of software applications, and connect to BACnet™ and edge and cloud-based applications
- Devices IP66 rated for indoor and outdoor use
- Five-tier security architecture delivers peace of mind for building owners and occupants



CLAIRITY™ Pro Mobile App

Makes configuration easy, no specialized devices or software to learn. Finish the job even faster by using the CLAIRITY™ Pro mobile app to start-up and commission a job with both feet safely on the ground.



nLight® AIR Adapter and ECLYPSE®

For regions that require advanced controls strategies like scheduling or demand response, nLight AIR easily connect the nLight® ECLYPSE® to aid in energy code compliance while also increasing the functionality of the system beyond compliance.

Visit www.lithonia.com for more information