

INSTALLATION INSTRUCTIONS

UNIVERSAL STEM KIT

FOR USE WITH MOST LITHONIA EXIT SIGNS

CAUTION: For safety and proper operation, read and follow instructions carefully before installation.

IMPORTANT SAFEGUARDS

1. READ AND FOLLOW ALL SAFETY INSTRUCTIONS

2. Before wiring to power supply, turn off electricity at fuse or circuit breaker.
3. Disconnect A.C. power before servicing.
4. All servicing should be performed by qualified personnel.
5. Consult your local building code for approved wiring and installation.

6. Do not use outdoors.
7. Do not mount near gas or electric heater.
8. Fixture must be grounded to avoid potential electric shock.
9. Equipment should be mounted in locations and at heights where it will not readily be subjected to tampering by unauthorized personnel.
10. The use of accessory equipment not recommended by the manufacturer may cause an unsafe condition.
11. Do not use this equipment for other than intended use.

SAVE THESE INSTRUCTIONS

IMPORTANT NOTE:

1. The use of a 4" octagon junction box (not supplied) is required for mounting.
2. All exit sign electronics must be in the exit sign housing.

Refer to product instruction sheet for wiring diagrams, maintenance instructions, and warranty information.

Installation: Pendant Mount

1. Attach screws ④ to mounting canopy ③ using retainer washers ⑤.
2. Thread swivel ② into mounting canopy ③. Secure swivel to mounting canopy with palnut ⑥. Attach threaded pendant ① into opposite end of swivel, using coupling ⑪.
3. Position universal mounting bracket ⑦ on 4" octagon j-box ⑧ (not provided) and fasten using screws provided with j-box.
4. Make wirenut connections to A.C. supply lines inside 4" j-box and feed pendant wires (not provided) through center hole in universal mounting bracket.
5. Using green ground screw ⑨ and cupwasher ⑩, make ground connection to universal mounting bracket ⑦.
6. Feed pendant wires through center hole in mounting canopy and pendant and attach mounting canopy ③ to universal mounting bracket ⑦ with screws ④.

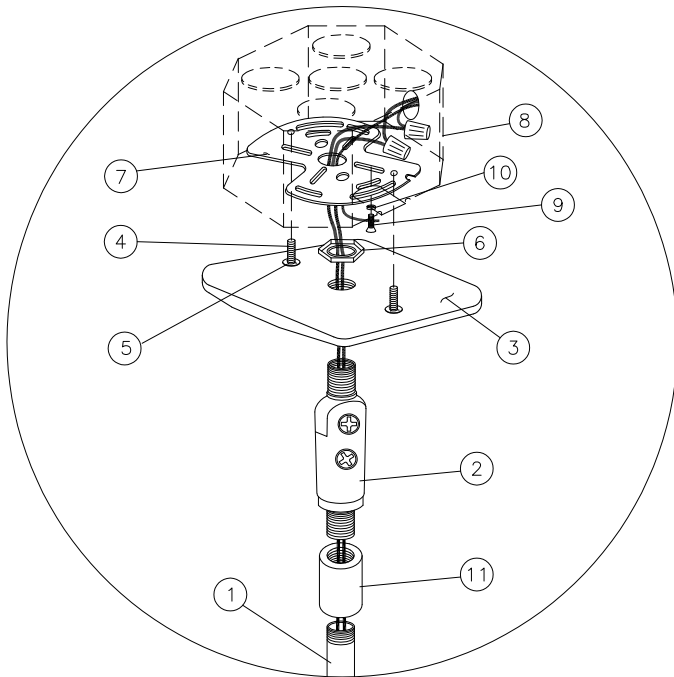

Figure 1
Pendant Mount
to Junction Box

Parts Description

- | | |
|------------------------|-----------------------------------|
| ① Pendant | ⑦ Universal Mounting Bracket |
| ② Swivel (Fig 1) | ⑧ 4" Octagon J-Box (not supplied) |
| ③ Mounting Canopy | ⑨ Green Ground Screw |
| ④ Screw, 8-32 X 1 1/4" | ⑩ Cupwasher |
| ⑤ Retaining Washer | ⑪ Coupling |
| ⑥ Palnut | |

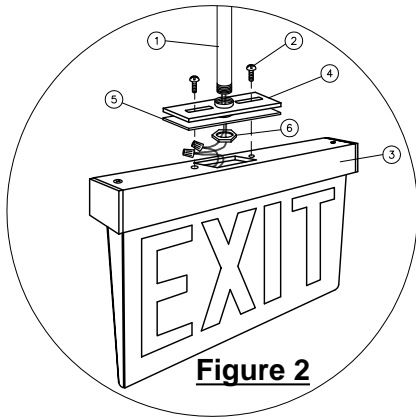

Figure 2

Parts Description

- ① Pendant
- ② Bracket Screws, 8-32 X 3/8"
- ③ Panel Assembly
- ④ Lamp Housing Bracket
- ⑤ Lamp Housing Gasket
- ⑥ Palnut
- ⑦ End Cap Screws, 8-32 X 3/8" C'snk
- ⑧ End Cap

Installation: Pendant to Precise LED (AC only) Exit Sign (see fig. 2)

Note: Pendant mounting requires that the polarized connector (plug half) (see Wiring Diagram on Precise Product Instruction sheet) be cut off approximately 3" behind plug and the leads be stripped to approximately 5/16" for wirenut connections.

1. Thread housing bracket ④ onto opposite end of pendant ①. Slide gasket ⑤ onto threaded end of pendant and position with housing bracket ④. Secure gasket ⑤ with palnut ⑥.
2. Select appropriate leads in panel assembly ③ and wirenut to pendant wires (using wirenuts provided).
3. Attach panel assembly ③ to lamp housing bracket ④ using screws ②. **Important Note:** Care should be taken to dress leads into lamp housing to leave clearance for palnut ⑥ and pendant ① when attaching panel assembly ③ to lamp housing bracket ④.
4. Set exit fixture plumb to floor by adjusting the angle of stem/swivel assembly and tighten screw on side of the swivel to lock securely in place.

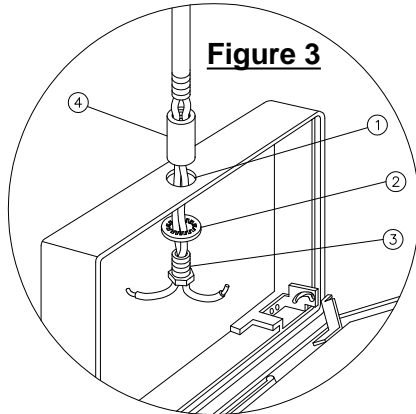

Figure 3

Parts Description

- ① Exit Housing knockout
- ② Lockwasher
- ③ Hex Nipple
- ④ Coupling

Installation: Pendant to Signature or Titan or EDG Exit Sign (see fig. 3).

1. Remove center knockout ① from top of exit housing.
2. Install lockwasher ② onto threaded hex nipple ③ and insert hex nipple through hole in top of exit housing.
3. Screw coupling ④ onto hex nipple ③ and screw one end of stem into coupling ④.
4. Set exit fixture plumb to floor by adjusting the angle of stem/swivel assembly and tighten screw on side of the swivel to lock securely in place.

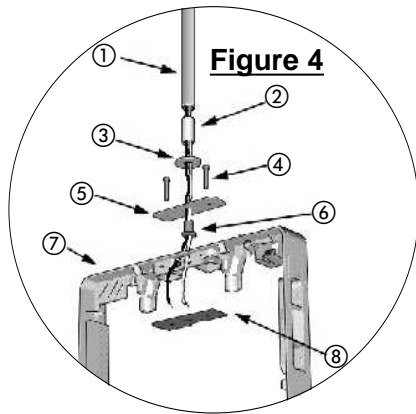

Figure 4

Parts Description

- ① Pendant
- ② Coupling
- ③ Washer
- ④ Screws, 8-18 X 1"
- ⑤ Upper Pendant Bracket
- ⑥ Hex Nipple
- ⑦ Exit Housing
- ⑧ Lower Pendant Bracket

Installation: Pendant to Quantum LHQM Combo (see fig. 4)

1. Attach hex nipple ⑥ through upper pendant bracket ⑤, washer ③, into coupling ②. Screw coupling ② assembly onto pendant ①.
2. Remove hole plug from top of housing ⑦. Thread jumper wires from coupling ② assembly into housing ⑦.
3. Attach lower pendant bracket ⑧ with thread cutting screws ④, capturing housing ⑦ between upper and lower brackets.
4. Set exit fixture plumb to floor by adjusting the angle of stem/swivel assembly, and tighten screw on side of the swivel to lock securely in place.

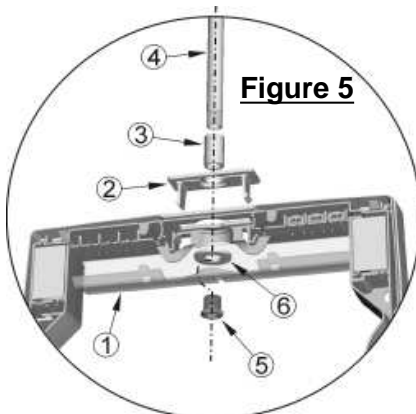

Figure 5

Parts Description

- ① Wire Cover
- ② Mounting Hole Cover
- ③ Coupling
- ④ Pendant
- ⑤ Hex Nipple
- ⑥ Washer

Installation: Pendant to Quantum Die-Cast LQC Exit Sign (see fig. 5)

1. Open wire cover ① at inside top of exit sign.
2. Remove upper mounting hole cover ② and drill 9/16" dia. hole through center knockout. Snap mounting hole cover ② into place.
3. Screw coupling ③ onto pendant ④. Attach hex nipple ⑤ through washer ⑥, and mounting hole cover ②, into coupling ③.
4. Make appropriate input connections inside wire cover ①. Dress wires and close wire cover securely.
5. Set exit fixture plumb to floor by adjusting the angle of stem/swivel assembly and tighten screw on side of the swivel to lock securely in place.



An AcuityBrands Company

EMERGENCY LIGHTING SYSTEMS

TEL: 800-334-8694 Fax: 770-981-8141 www.lithonia.com